IMPLEMENTING 16-BIT PWM USING THE PCA

Relevant Devices

This application note applies to the following devices:

C8051F000, C8051F001, C8051F002,
C8051F005, C8051F006, C8051F010, C8051F011,
and C8051F012.

Introduction

Pulse-width modulated (PWM) waveforms are often used in closed-loop feedback and control applications, such as controlling the on/off state of a heating element used to regulate the temperature of a laser in a DWDM (Dense Wavelength Division Multiplexing) application. In some applications, the built-in 8-bit PWM mode of the Programmable Counter Array (PCA) provides insufficient resolution for the task. This application note describes how to implement a PWM waveform achieving 16-bit resolution using the PCA in 'High-Speed Output' mode with minimal software overhead. Software examples in 'C' and assembly are provided at the end of this note.

Background

Figure 1 shows an example PWM waveform. The frequency of the PWM signal of the class used in feedback control applications is largely unimportant, as long as the waveform is 'fast enough', such that the step response of the control system is much slower than one period of the PWM signal. Signal information is encoded instead in the *duty cycle* of the waveform, the ratio of the time the waveform is high over one period of the PWM signal. The input to the PWM implementation is a number, usually an integer, that is proportional to the duty cycle desired at the output.

Implementation

There are many methods for implementing a PWM waveform in an 8051-based design: software loops, polled or interrupt-driven timers, etc. The examples in this note use the Programmable Counter Array (PCA). Using the PCA for this application results in a substantial reduction in CPU bandwidth requirements over any polled scheme (software or timer-based), and eliminates timing jitter caused by

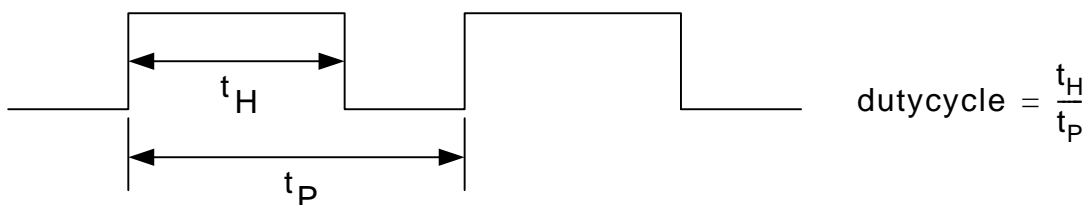

Figure 1. Example PWM Waveform

variable interrupt latency in interrupt-driven timer-based designs.

An Introduction to the PCA

The PCA consists of a single 16-bit counter/timer and five capture/compare modules, as shown in Figure 2. The counter/timer has a 16-bit timer/counter register (PCA0H:PCA0L), an associated mode register (PCA0MD), which selects the time base, and a control register (PCA0CN), which contains the timer/counter run control and the modules' capture/compare flags. Each capture/compare module has a configuration register (PCA0CPMx) which selects the module's mode (Edge-triggered Capture, Software Timer, High-Speed Output, or PWM) and a 16-bit capture/compare register (PCA0CPHn:PCA0CPLn).

Because the capture/compare modules share a common time base, they can operate in concert, to provide phase-locked excitation waveforms for

motor control, for example. Or, because each module has its own control and capture/compare registers, it can operate independently of the other modules, as long as the routines for any module do not affect the shared time base (by stopping or resetting the counter/timer or by changing the counter/timer clock source).

The examples in this note configure the PCA modules to act independently; the routines for the allocated module affect only the configuration register and the capture/compare register for that module. The PCA Mode Register (PCA0MD) is configured once, then left alone, and the timer/counter register (PCA0H:PCA0L) is left free-running.

Selecting the PCA Time Base

The PCA time base can be derived from one of four sources: SYSCLK / 12, SYSCLK / 4, Timer0 overflows, or high-to-low transitions on an external pin, ECI. A block diagram of the PCA counter/timer is

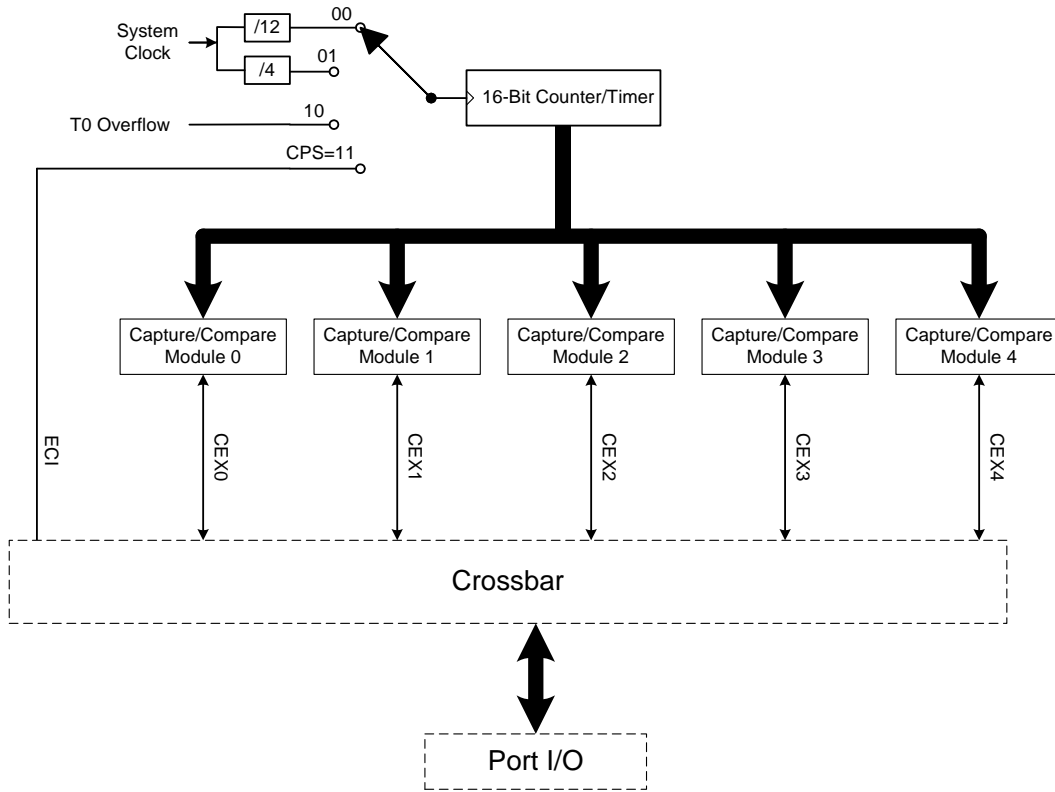

Figure 2. PCA Block Diagram

shown in Figure 3.

As will be shown in the following sections, the selection of the PCA time base determines the resulting frequency of the PWM waveform. As mentioned earlier, the frequency of the PWM waveform is generally not important, so long as it is 'fast enough'.

One timing option that is not immediately obvious is that the PCA can be clocked at the SYSCLK rate by selecting Timer0 overflows as the PCA clock source, and setting Timer0 in 8-bit auto-reload mode with a reload value of '0xFF'.

The examples in this note all configure the PCA to use $\text{SYSCLK} / 4$ as the PCA clock source.

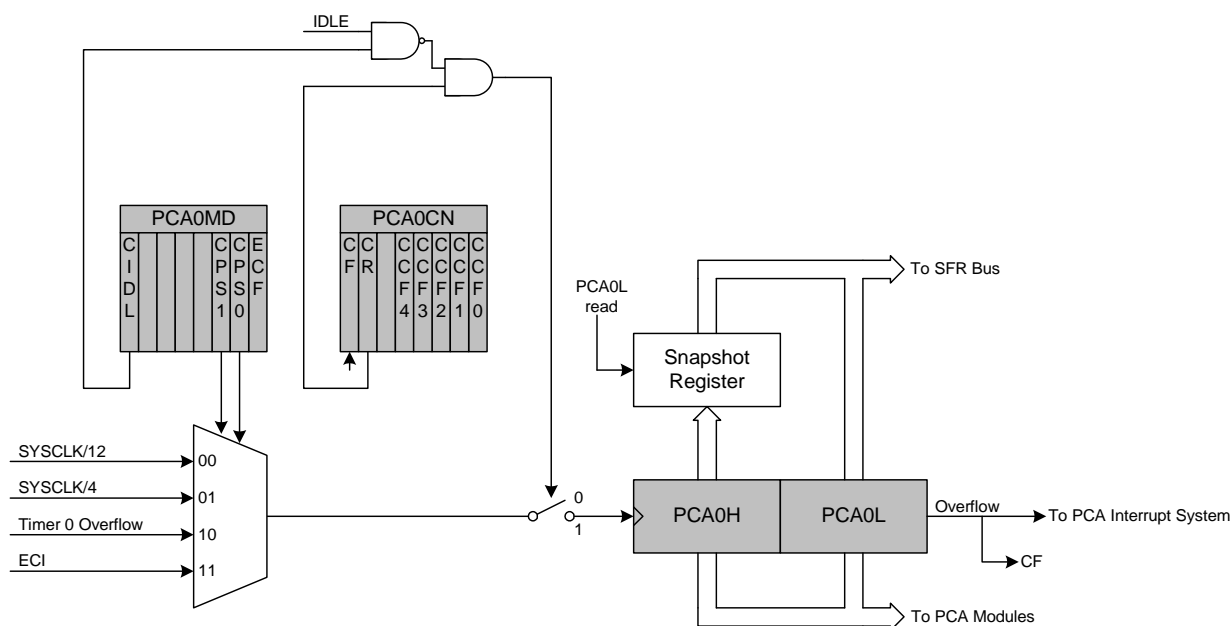

Figure 3. PCA Counter/Timer Block Diagram

loaded with the compare value for the next rising-edge, which is zero (0x0000). This is shown in Figure 7. Note that the period of the PWM waveform is 65536 PCA clocks.

The duty cycle (in %) is given by:

$$\text{duty cycle} = \frac{\text{PWM}}{65536} \times 100$$

The minimum and maximum allowed duty cycles are determined by the maximum time it takes to update the compare value after *CEXn* changes (which triggers the process interrupt). In both the ‘C’ example code and the assembly example code (‘pwm16_1.c’ and ‘pwm16_1.asm’ respectively), the minimum value for PWM is 7 PCA clocks (28 SYSCLK cycles in this case). This results in minimum and maximum duty cycle values of 0.01 % and 99.99 % respectively. The resolution of the duty cycle (in %) is:

$$\text{resolution} = \frac{1}{65536} \times 100 = 0.0015$$

or about 15 ppm (parts per million).

The CPU overhead required to process these interrupts is minimal. In the assembly example, pro-

cessing both edges takes a total of 41 SYSCLK cycles, not counting the interrupt call and vector itself. Both edges must be processed every 65,536 PCA clocks, or $65,536 * 4 = 262,144$ SYSCLKs, if the PCA clock is equal to $\text{SYSCLK} / 4$. CPU bandwidth consumed (in %) is equal to $(41 / 262,144 * 100) = 0.015$ %.

Also note that the CPU can be left in IDLE mode, as is done in the examples, since the PCA module interrupt will ‘wake up’ the core when required for processing.

The duty cycle can be changed by a single 16-bit write to the variable *PWM* in the examples.

n-Bit PWM Using the PCA

A generalized case of 16-bit PWM, we present n-Bit PWM for applications requiring more than 8-bits of precision but less than 16-bits of precision. One motivation for adopting the n-Bit approach is to achieve a higher output frequency from the PWM than can be obtained in the 16-bit implementation.

In this example (‘PWMn_1.c’), two 16-bit variables are used: *PWM_HIGH*, which holds the number of PCA clocks for the output waveform to remain high, and *PWM_LOW*, which correspondingly holds the number of PCA clocks for the output waveform to remain low. The period of the

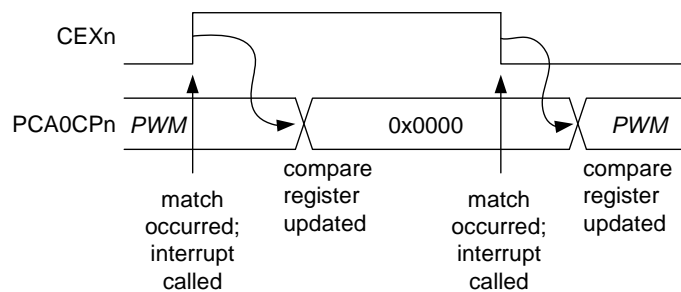

Figure 7. Capture/Compare Register Loading for 16-Bit PWM

output waveform is given by the sum of these two variables:

$$\text{period} = \text{PWMHIGH} + \text{PWMLOW}$$

The duty cycle (in %) is given by:

$$\text{duty cycle} = \frac{\text{PWMHIGH}}{\text{PWMHIGH} + \text{PWMLOW}} \times 100$$

The resolution of the duty cycle (in %) is:

$$\text{resolution} = \frac{1}{\text{PWMHIGH} + \text{PWMLOW}} \times 100$$

Similar to the 16-bit PWM case, the interrupt handler is implemented in two states, one for the rising-edge and one for the falling-edge. The primary difference is that in the 16-bit case, a constant (*PWM* or zero) was loaded into the PCA module's compare registers. In the n-Bit case, a constant (*PWM_HIGH* or *PWM_LOW*) is added to the current value in the module's compare register. The addition operation takes a few more cycles than loading a constant, which restricts the minimum high or low time of the output waveform a little more than the corresponding 16-bit solution.

Note: the n-Bit PWM solution can be used to generate a waveform of an arbitrary frequency by programming the appropriate high and low values into *PWM_HIGH* and *PWM_LOW*.

Software Examples

PWM8_1.c

```
//-----  
// PWM8_1.c  
//-----  
//  
// AUTH: BW  
//  
// Target: C8051F000, F001, F002, F005, F006, F010, F011, or F012  
// Tool chain: KEIL C51  
//  
// Description:  
//  
// Example source code for implementing 8-bit PWM.  
// The PCA is configured in 8-bit PWM mode using  
// SYSCLK/4 as its time base. <PWM> holds the number of  
// PCA cycles for the output waveform to remain low per 256-  
// count period. The waveform is high for (256 - PWM) cycles.  
// The duty cycle of the output is equal to (256 - PWM) / 256.  
//  
// Because the 8-bit PWM is handled completely in hardware,  
// no CPU cycles are expended in maintaining a fixed duty  
// cycle. Altering the duty cycle requires a single 8-bit  
// write to the high byte of the module's compare register,  
// PCA0CP0H, in this example.  
//  
// Achievable duty cycle ranges are 0.38% (PCA0CP0H = 0xff)  
// to 100% (PCA0CP0H = 0x00).  
//  
//-----  
// Includes  
//-----  
  
#include <c8051f000.h> // SFR declarations  
  
//-----  
// Global CONSTANTS  
//-----  
  
#define PWM 0x80 // Number of PCA clocks for  
                // waveform to be low  
                // duty cycle = (256 - PWM) / 256  
                // Note: this is an 8-bit value  
  
//-----  
// Function PROTOTYPES  
//-----  
  
void main (void);  
  
//-----  
// MAIN Routine  
//-----  
  
void main (void) {
```

```

WDTCN = 0xde;           // Disable watchdog timer
WDTCN = 0xad;

OSCICN = 0x07;         // set SYSCLK to 16MHz,
                       // internal osc.

XBR0 = 0x08;           // enable CEX0 at P0.0
XBR2 = 0x40;           // enable crossbar and weak
                       // pull-ups

PRT0CF = 0x01;         // set P0.0 output state to
                       // push-pull
PRT1CF = 0x20;         // set P1.6 output to
                       // push-pull (LED)

// configure the PCA
PCA0MD = 0x02;         // disable CF interrupt
                       // PCA time base = SYSCLK / 4
PCA0CPL0 = PWM;        // initialize PCA PWM value
PCA0CPH0 = PWM;
PCA0CPM0 = 0x42;       // CCM0 in 8-bit PWM mode
PCA0CN = 0x40;         // enable PCA counter

while (1) {
    PCON |= 0x01;      // set IDLE mode
}
} // *** END OF FILE ***

```

PWM16_1.c

```

//-----
// PWM16_1.c
//-----
//
// AUTH: BW
//
// Target: C8051F000, F001, F002, F005, F006, F010, F011, or F012
// Tool chain: KEIL C51
//
// Description:
//
// Example source code for implementing 16-bit PWM.
// The PCA is configured in high speed output mode using
// SYSCLK/4 as its time base. <PWM> holds the number of
// PCA cycles for the output waveform to remain high. The
// waveform is low for (65536 - PWM) cycles. The duty
// cycle of the output is equal to PWM / 65536.
//
// Due to interrupt service times, there are minimum and
// maximum values for PWM, and therefore the duty cycle,
// depending on interrupt service times. On the Keil C51
// compiler (Eval version), the minimum PWM value is 7
// PCA clocks; the maximum value is 65530. This equates
// to a minimum duty cycle of 0.01% and a maximum duty
// cycle of 99.99%. This assumes a PCA time base of SYSCLK/4
// and no other interrupts being serviced.
//

```

AN107

```
//-----  
// Includes  
//-----  
  
#include <c8051f000.h> // SFR declarations  
  
//-----  
// Global CONSTANTS  
//-----  
  
#define PWM_START0x4000 // starting value for the PWM  
// high time  
sbit PWM_OUT = P0^0; // define PWM output port pin  
  
//-----  
// Function PROTOTYPES  
//-----  
  
void main (void);  
void PCA_ISR (void); // PCA Interrupt Service Routine  
  
//-----  
// Global VARIABLES  
//-----  
unsigned PWM = PWM_START; // Number of PCA clocks for  
// waveform to be high  
// duty cycle = PWM / 65536  
// Note: this is a 16-bit value  
  
//-----  
// MAIN Routine  
//-----  
  
void main (void) {  
  
    WDTCN = 0xde; // Disable watchdog timer  
    WDTCN = 0xad;  
  
    OSCICN = 0x07; // set SYSCLK to 16MHz,  
// internal osc.  
  
    XBR0 = 0x08; // enable CEX0 at P0.0  
    XBR2 = 0x40; // enable crossbar and weak  
// pull-ups  
  
    PRT0CF = 0x01; // set P0.0 output state to  
// push-pull  
    PRT1CF = 0x20; // set P1.6 output to  
// push-pull (LED)  
  
    // configure the PCA  
    PCA0MD = 0x02; // disable CF interrupt  
// PCA time base = SYSCLK / 4  
    PCA0CPL0 = (0xff & PWM); // initialize PCA compare value  
    PCA0CPH0 = (0xff & (PWM >> 8));  
    PCA0CPM0 = 0x4d; // CCM0 in High Speed output mode  
  
}
```

```

EIE1 |= 0x08;           // enable PCA interrupt

EA = 1;                // Enable global interrupts

PCA0CN = 0x40;        // enable PCA counter

while (1) {
    PCON |= 0x01;     // set IDLE mode
}

//-----
// PCA_ISR
//-----
//
// This ISR is called when the PCA CCM0 obtains a match
// PWM_OUT is the CEX0 port pin that holds the state of the current edge:
// 1 = rising edge; 0 = falling edge
// On the rising edge, the compare registers are loaded with PWM_HIGH.
// On the falling edge, the compare registers are loaded with zero.
//
void PCA_ISR (void) interrupt 9
{
    if (CCF0) {
        CCF0 = 0;           // clear compare indicator
        if (PWM_OUT) {     // process rising edge

            PCA0CPL0 = (0xff & PWM); // set next match to PWM
            PCA0CPH0 = (0xff & (PWM >> 8));

        } else {          // process falling edge

            PCA0CPL0 = 0; // set next match to zero
            PCA0CPH0 = 0;

        }

    } else if (CCF1) {    // handle other PCA interrupt
        CCF1 = 0;        // sources
    } else if (CCF2) {
        CCF2 = 0;
    } else if (CCF3) {
        CCF3 = 0;
    } else if (CCF4) {
        CCF4 = 0;
    } else if (CF) {
        CF = 0;
    }
}
// *** END OF FILE ***

```

PWM16_1.asm

```

;-----
;  CYGNAL, INC.
;
;
;  FILE NAME   :   pwm16_1.ASM
;  TARGET MCU  :   C8051F000, F001, F002, F005, F006, F010, F011, or F012

```

AN107

```
; DESCRIPTION:      Example source code for implementing 16-bit PWM.
;                  The PCA is configured in high speed output mode using
;                  SYSCLK/4 as its time base.  PWM holds the number of
;                  PCA cycles for the output waveform to remain high.  The
;                  waveform is low for (65536 - PWM) cycles.  The duty
;                  cycle of the output is equal to PWM / 65536.
;
;                  Due to interrupt service times, the minimum value for
;                  PWM is 7 PCA cycles, and the maximum value is 65529.
;                  This equates to a minimum duty cycle of 0.01068% and a
;                  maximum duty cycle of 99.9893%.
;
;                  If the PCA time base is changed to SYSCLK / 12, the min and
;                  max values for PWM change to 3 and 65533 respectively,
;                  for min and max duty cycles of 0.0046% and 99.9954%
;                  respectively.
;
;                  Processing the rising edge interrupt handler takes 18 cycles.
;                  Processing the falling edge interrupt handler takes 19 cycles.
;
;                  One interrupt handler is called for each edge, and there are
;                  2 edges for every 65536 PCA clocks.  Using SYSCLK / 4 as the
;                  PCA time base, that means that 37 cycles are consumed for
;                  edge maintenance for every (65536 * 4) = 262,144 SYSCLK
;                  cycles, not counting vectoring the interrupt.
;                  CPU utilization is (37 / 262,144)*100% = 0.0141%
;
;                  Using SYSCLK / 12 as the PCA timebase, 37 cycles are
;                  consumed for edge maintenance for every (65536 * 12) =
;                  786,432 SYSCLK cycles.  CPU utilization is (37 / 786,432)
;                  = 0.0047%.
;
;                  The period of the waveform is 65536 PCA clocks.  Using
;                  SYSCLK / 4 as the PCA time base, the period is 262,144 SYSCLK
;                  cycles.  Using the default internal oscillator at 2MHz, the
;                  period is 131ms (7.6Hz).  Using the 16MHz internal
;                  oscillator (as in this example), the period is 16.4us
;                  (61 Hz).
;
;                  Using SYSCLK / 12 as the PCA time base, the period is
;                  65536 * 12 = 786,432 SYSCLK cycles.  Using the default
;                  internal oscillator at 2MHz, the period is 393ms (2.5Hz).
;                  Using the 16MHz internal oscillator, the period is 49.2ms
;                  (20Hz).
;
;                  In this example, the output is routed to P0.0, which is
;                  also labeled 'PWM_OUT'.
;
;-----
;
;-----
; EQUATES
;-----

$MOD8F000

PWM    EQU    32768                ; Number of PCA clocks for waveform
;                                     ; to be high
;                                     ; duty cycle = PWM / 65536
```

```

; max = 65529 (99.9893% duty cycle)
; min = 7 (0.01068% duty cycle)
; Note: this is a 16-bit constant

PWM_OUT EQU P0.0 ; define PWM output port pin

;-----
; RESET AND INTERRUPT VECTOR TABLE
;-----

CSEG
    org 00h
    ljmp Main

    org 04bh
    ljmp PCA_ISR ; PCA Interrupt Service Routine

;-----
; MAIN PROGRAM CODE
;-----
    org 0b3h ; start at end of interrupt handler
; space

Main:
    ; Disable watchdog timer
    mov WDTCN, #0deh
    mov WDTCN, #0adh

    ; Enable the Internal Oscillator at 16 MHz
    mov OSCICN, #07h

    ; Enable the Crossbar, weak pull-ups enabled
    mov XBR0, #08h ; route CEX0 to P0.0
    mov XBR2, #40h

    orl PRT0CF, #01h ; Configure Port 0.0 as Push-Pull

    ; Configure the PCA
    mov PCA0MD, #02h ; disable cf interrupt,
; PCA time base = SYSCLK/4
    mov PCA0CPL0, #LOW(PWM) ; initialize the PCA compare value
    mov PCA0CPH0, #HIGH(PWM)
    mov PCA0CPM0, #4dh ; CCM0 in High Speed output mode

    ; Enable interrupts
    orl EIE1, #08h ; Enable PCA interrupt
    setb EA ; Enable global interrupts

    mov PCA0CN, #40h ; enable PCA counter

    jmp $

;-----
; CCF0 Interrupt Vector
;
;
; This ISR is called when the PCA CCM0 obtains a match
; PWM_OUT is the CEX0 port pin that holds the state of the current edge:
; 1 = rising edge; 0 = falling edge
; On the rising edge, the compare registers are loaded with PWM_HIGH.

```

AN107

; On the falling edge, the compare registers are loaded with zero.

```
PCA_ISR:
    jbc    CCF0, CCF0_HNDL          ; handle CCF0 comparison
    jbc    CCF1, PCA_STUB          ; stub routines
    jbc    CCF2, PCA_STUB
    jbc    CCF3, PCA_STUB
    jbc    CCF4, PCA_STUB
    jbc    CF,    PCA_STUB
```

```
PCA_STUB:
PCA_ISR_END:
    reti
```

```
CCF0_HNDL:
    jnb    PWM_OUT, CCF0_FALL      ; handle rising edge
```

```
CCF0_RISE:
    mov    PCA0CPL0, #LOW(PWM)
    mov    PCA0CPH0, #HIGH(PWM)

    reti
```

```
CCF0_FALL:                          ; handle falling edge
    mov    PCA0CPL0, #00
    mov    PCA0CPH0, #00

    reti
```

```
; rising edge takes 4+3+11 = 18 cycles
; falling edge takes 4+4+11 = 19 cycles
```

```
;-----
; END
;-----
```

```
END
; *** END OF FILE ***
```

PWMn_1.c

```
//-----
// PWMn_1.c
//-----
//
// AUTH: BW
//
// Target: C8051F000, F001, F002, F005, F006, F010, F011, or F012
// Tool chain: KEIL C51
//
// Description:
//
//         Example source code for implementing an n-bit PWM.
//         The PCA is configured in high speed output mode using
//         SYSCLK/4 as its time base. <PWM_HIGH> holds the number of
//         PCA cycles for the output waveform to remain high.
//         <PWM_LOW> holds the number of PCA cycles for the output
//         waveform to remain low. The duty cycle of the output
//         is equal to PWM_HIGH / (PWM_HIGH + PWM_LOW).
```

```

//
//      Due to interrupt service times, there are minimum and
//      maximum values for PWM_HIGH and PWM_LOW, and therefore
//      the duty cycle, depending on interrupt service times.
//      Regardless of the efficiency of the compiler, duty
//      cycles between 1% and 99% should be very easy to achieve.
//
//      With the eval version of the Keil compiler, the minimum
//      high and low counts are 20 PCA cycles each (max frequency
//      is about 100kHz w/ 16MHz internal SYSCLK). This assumes
//      no other interrupts being serviced, and PCA time base is
//      SYSCLK / 4.
//
//-----
// Includes
//-----
#include <c8051f000.h>                // SFR declarations

//-----
// Global CONSTANTS
//-----

#define PWM_START    0x8000          // starting value for the
// PWM_HIGH time and PWM_LOW time

sbit  PWM_OUT = P0^0;              // define PWM output port pin

//-----
// Function PROTOTYPES
//-----

void main (void);
void PCA_ISR (void);              // PCA Interrupt Service Routine

//-----
// Global VARIABLES
//-----
unsigned PWM_HIGH = PWM_START;     // Number of PCA clocks for
// waveform to be high
unsigned PWM_LOW = ~PWM_START;     // Number of PCA clocks for
// waveform to be low
// duty cycle =
// PWM_HIGH / (PWM_HIGH + PWM_LOW)

//-----
// MAIN Routine
//-----

void main (void) {

    WDTCN = 0xde;                  // Disable watchdog timer
    WDTCN = 0xad;

    OSCICN = 0x07;                 // set SYSCLK to 16MHz,
// internal osc.

    XBR0 = 0x08;                   // enable CEX0 at P0.0
    XBR2 = 0x40;                   // enable crossbar and weak

```

AN107

```

// pull-ups
PRT0CF = 0x01; // set P0.0 output mode to
                // push-pull
PRT1CF = 0x20; // set P1.6 output to
                // push-pull (LED)

// configure the PCA
PCA0MD = 0x02; // disable CF interrupt
                // PCA time base = SYSCLOCK / 4
PCA0CPL0 = (0xff & PWM_HIGH); // initialize PCA compare value
PCA0CPH0 = (0xff & (PWM_HIGH >> 8));
PCA0CPM0 = 0x4d; // CCM0 in High Speed output mode

EIE1 |= 0x08; // enable PCA interrupt

EA = 1; // Enable global interrupts

PCA0CN = 0x40; // enable PCA counter

while (1) {
    PCON |= 0x01; // set IDLE mode
}

//-----
// PCA_ISR
//-----
//
// This ISR is called when the PCA CCM0 obtains a match
// PWM_OUT is the CEX0 port pin that holds the state of the current edge:
// 1 = rising edge; 0 = falling edge
// On the rising edge, the compare registers are updated to trigger for the
// next falling edge.
// On the falling edge, the compare registers are updated to trigger for the
// next rising edge.
//
void PCA_ISR (void) interrupt 9
{
    unsigned temp; // holding value for 16-bit math

    if (CCF0) {
        CCF0 = 0; // clear compare indicator
        if (PWM_OUT) { // process rising edge

            // update compare match for next falling edge
            temp = (PCA0CPH0 << 8) | PCA0CPL0; // get current compare value
            temp += PWM_HIGH; // add appropriate offset

            PCA0CPL0 = (0xff & temp); // replace compare value
            PCA0CPH0 = (0xff & (temp >> 8));

        } else { // process falling edge

            // update compare match for next rising edge
            temp = (PCA0CPH0 << 8) | PCA0CPL0; // get current compare value
            temp += PWM_LOW; // add appropriate offset
        }
    }
}

```

```
        PCA0CPL0 = (0xff & temp);           // replace compare value
        PCA0CPH0 = (0xff & (temp >> 8));

    }
} else if (CCF1) {                          // handle other PCA interrupt
    CCF1 = 0;                               // sources
} else if (CCF2) {
    CCF2 = 0;
} else if (CCF3) {
    CCF3 = 0;
} else if (CCF4) {
    CCF4 = 0;
} else if (CF) {
    CF = 0;
}
}
// *** END OF FILE ***
```

Silicon Labs

Simplicity Studio™4

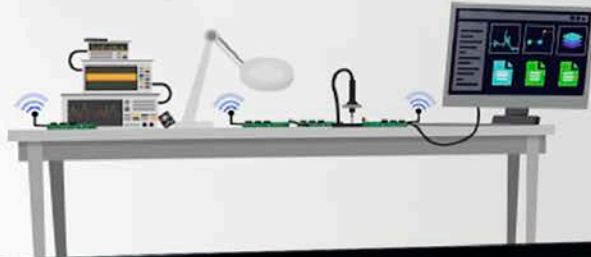

Simplicity Studio

One-click access to MCU and wireless tools, documentation, software, source code libraries & more. Available for Windows, Mac and Linux!



IoT Portfolio
www.silabs.com/IoT



SW/HW
www.silabs.com/simplicity



Quality
www.silabs.com/quality



Support and Community
community.silabs.com

Disclaimer

Silicon Labs intends to provide customers with the latest, accurate, and in-depth documentation of all peripherals and modules available for system and software implementers using or intending to use the Silicon Labs products. Characterization data, available modules and peripherals, memory sizes and memory addresses refer to each specific device, and "Typical" parameters provided can and do vary in different applications. Application examples described herein are for illustrative purposes only. Silicon Labs reserves the right to make changes without further notice and limitation to product information, specifications, and descriptions herein, and does not give warranties as to the accuracy or completeness of the included information. Silicon Labs shall have no liability for the consequences of use of the information supplied herein. This document does not imply or express copyright licenses granted hereunder to design or fabricate any integrated circuits. The products are not designed or authorized to be used within any Life Support System without the specific written consent of Silicon Labs. A "Life Support System" is any product or system intended to support or sustain life and/or health, which, if it fails, can be reasonably expected to result in significant personal injury or death. Silicon Labs products are not designed or authorized for military applications. Silicon Labs products shall under no circumstances be used in weapons of mass destruction including (but not limited to) nuclear, biological or chemical weapons, or missiles capable of delivering such weapons.

Trademark Information

Silicon Laboratories Inc.®, Silicon Laboratories®, Silicon Labs®, SiLabs® and the Silicon Labs logo®, Bluegiga®, Bluegiga Logo®, Clockbuilder®, CMEMS®, DSPPLL®, EFM®, EFM32®, EFR®, Ember®, Energy Micro, Energy Micro logo and combinations thereof, "the world's most energy friendly microcontrollers", Ember®, EZLink®, EZRadio®, EZRadioPRO®, Gecko®, ISOModem®, Precision32®, ProSLIC®, Simplicity Studio®, SiPHY®, Telegesis, the Telegesis Logo®, USBXpress® and others are trademarks or registered trademarks of Silicon Labs. ARM, CORTEX, Cortex-M3 and THUMB are trademarks or registered trademarks of ARM Holdings. Keil is a registered trademark of ARM Limited. All other products or brand names mentioned herein are trademarks of their respective holders.



SILICON LABS

Silicon Laboratories Inc.
400 West Cesar Chavez
Austin, TX 78701
USA

<http://www.silabs.com>